

blueberry

Intelligent data acquisition for wind energy,
meteorology and industry



The blueberry

- Integrated webserver for a simple, intuitive user interface
- Direct access via GSM or Internet (GPRS/DSL)
- Automatic transmission of messages and measuring data via e-mail, SMS or FTP
- Intelligent sensor operation monitoring
- Digital measuring inputs for frequency or counting pulses
- Analog measuring inputs via input modules
- Serial RS 485 port for connection of ultrasonic anemometers or other sensors with serial output
- Ethernet port for fast data transmission to a PC (notebook, desktop or pocket PC) or for integration in a PC network (LAN)
- Switching outputs for control tasks or for triggering alarms
- Large, expandable data memory
- Can be modularly expanded for a large number of measuring inputs

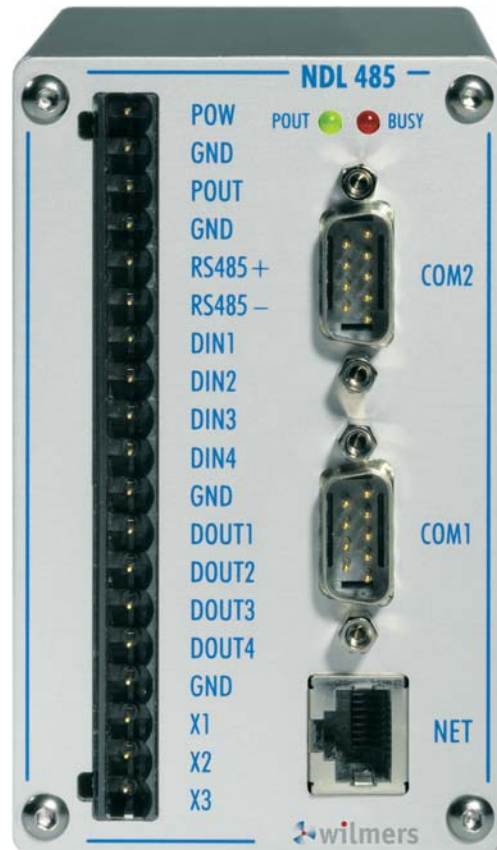

Actual size

The network-capable **blueberry NDL 485** data logger was developed for complex measurements in the fields of wind energy, meteorology and industry. It is characterized by a broad range of communication options, an intelligent modular design and low current consumption. This all makes it the ideal basis for an autonomous measuring station with a solar power supply.

modular and network-capable

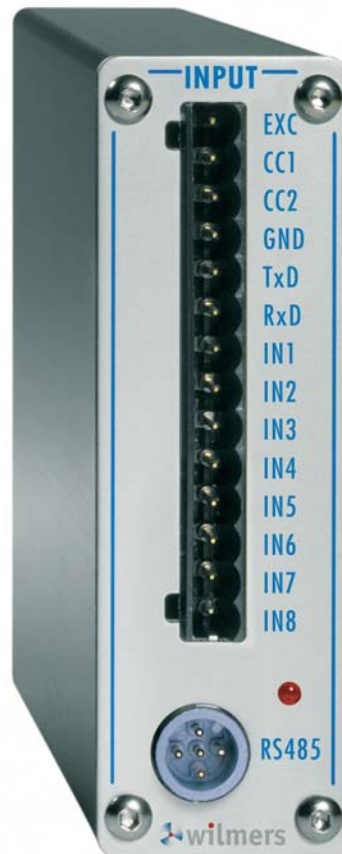

The **blueberry** concept enables expansion to a large number of input modules. Each module is equipped with 8 measuring inputs, which can be configured as analog or digital by the user, and an RS 232 port for additional serial sensors.

The GSM module is based on state-of-the-art modem technology. It is used both for convenient data communications via GSM and for the integration of the data logger in the Internet via GPRS.

With additional modules, the **blueberry** can be flexibly expanded to a powerful data acquisition system. The modules have rugged, compact aluminum top-hat rail housings. All connections and controls are arranged on the front of the housing for easy access.

One for all ...

Wind Energy

Complex wind sites and great hub heights require wind measuring technology that grows with the task. Detailed turbulence measurements with ultrasonic anemometers are just as possible with the **blueberry** as the recording of high-resolution wind profiles.

Meteorology

For systems with many measuring channels, the **blueberry** is equipped with a large memory capacity. Automatic data transmission via GPRS to a central file server simplifies data acquisition of measuring stations in large networks.

Environmental Monitoring

When critical measured values occur, the **blueberry** triggers alarm signals. All measured values and switching processes are logged by the data logger. A typical application is climate monitoring in warehouses.

Industry

The **blueberry** can be optimally integrated in industrial networks via an Ethernet port. Using an Internet browser, the current measured values are then accessible as numeric values and diagrams at every workplace within the network.

... and all for one

The **blueberry** opens up new dimensions in modern data acquisition. Its communicative design offers a high level of operating flexibility that goes beyond classic applications. From simple wind site assessment to climate research and online weather stations – all possibilities are open to you.

without limits

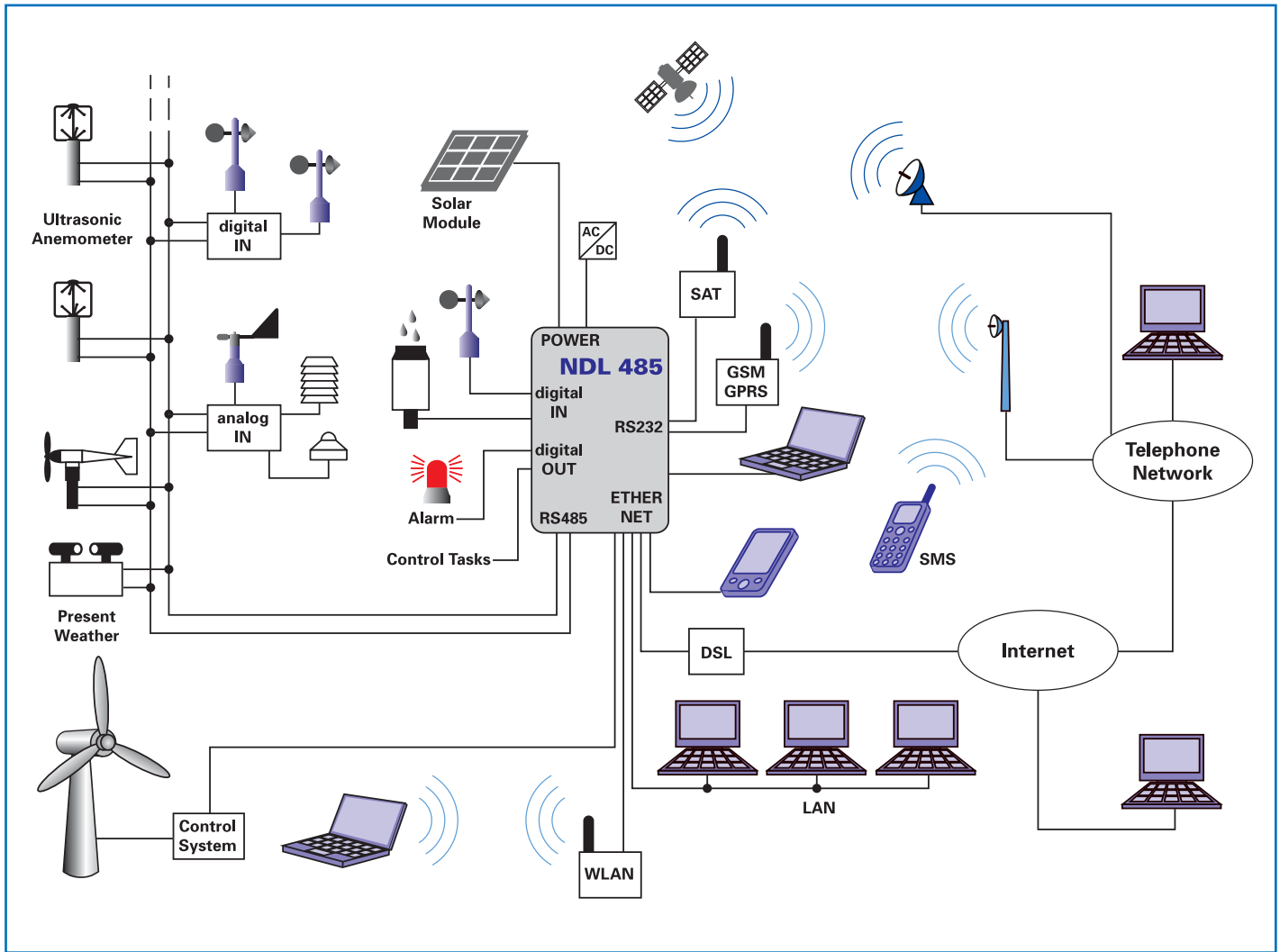

In meteorology, climate research and wind energy research, sensors with serial ports enjoy increasing popularity. Several serial sensors can be connected to the **blueberry** simultaneously via the RS485 bus system. Data output ranges from local read-out with a pocket PC to remote data transmission via satellite or DSL. Measuring data can be transmitted over the Internet – quickly and securely.

blueberry. It's so simple.

An Internet browser under Windows/Mac/Linux is all that's necessary to access the data logger. No special PC software is required, and maximum security is guaranteed at all times with the multi-level password protection.

The **blueberry** generates easy-to-understand graphs and charts from the measuring data. Current measuring data, graphs and charts can automatically be transmitted to a website. Typical applications for this purpose include online weather stations or regular measuring data uploads to a central file server.

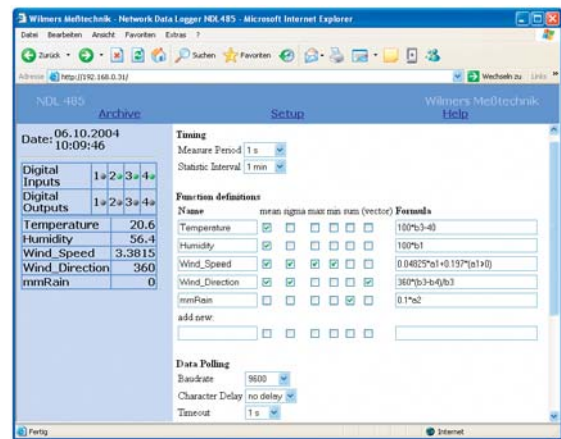
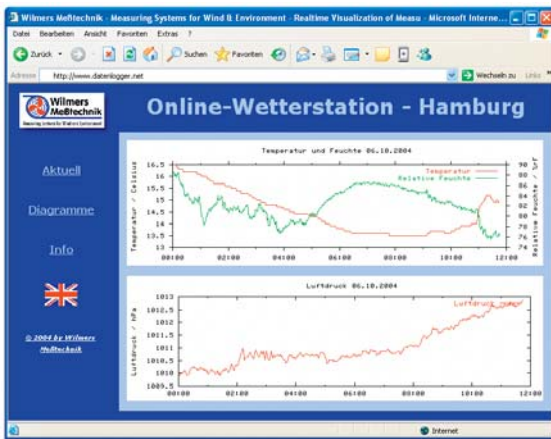

wilmers products have stood for quality and reliability internationally since 1991. You receive a 3-years warranty on all **blueberry** components.

Your distributor



Capturing the Future